



TESS120 DATASHEET

INTERNAL RAIL-GUIDED TENSION SYSTEM

Designed to minimise the load imposed on your structure.
Any angle, any direction, anywhere.

Where tensioned fabric is required for lighter structures, the TESS 120 is the answer. The aluminium frame retains the tension force of the blind, and the weight of the system is distributed via multiple fixing points. Unlimited colour finishes and a wide range of fabrics make it suitable for any project. The single barrel mechanism keeps the fabric constantly under tension and produces a smooth, quiet travel.

- Single barrel tension system
- Any angle, any direction
- Minimal load on building
- Guide rails for maximum stability
- Reliable and robust

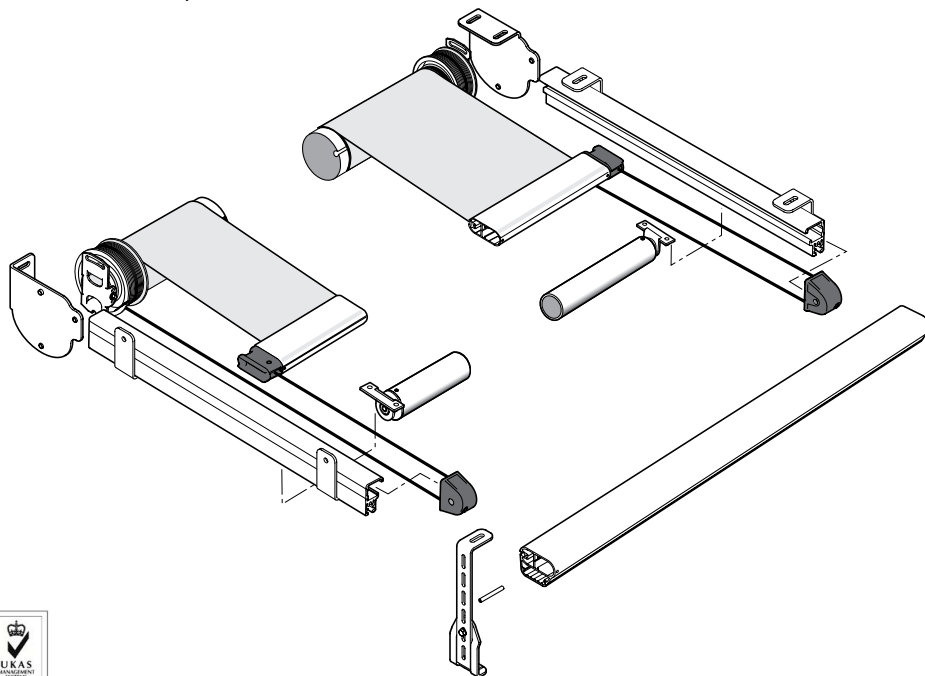

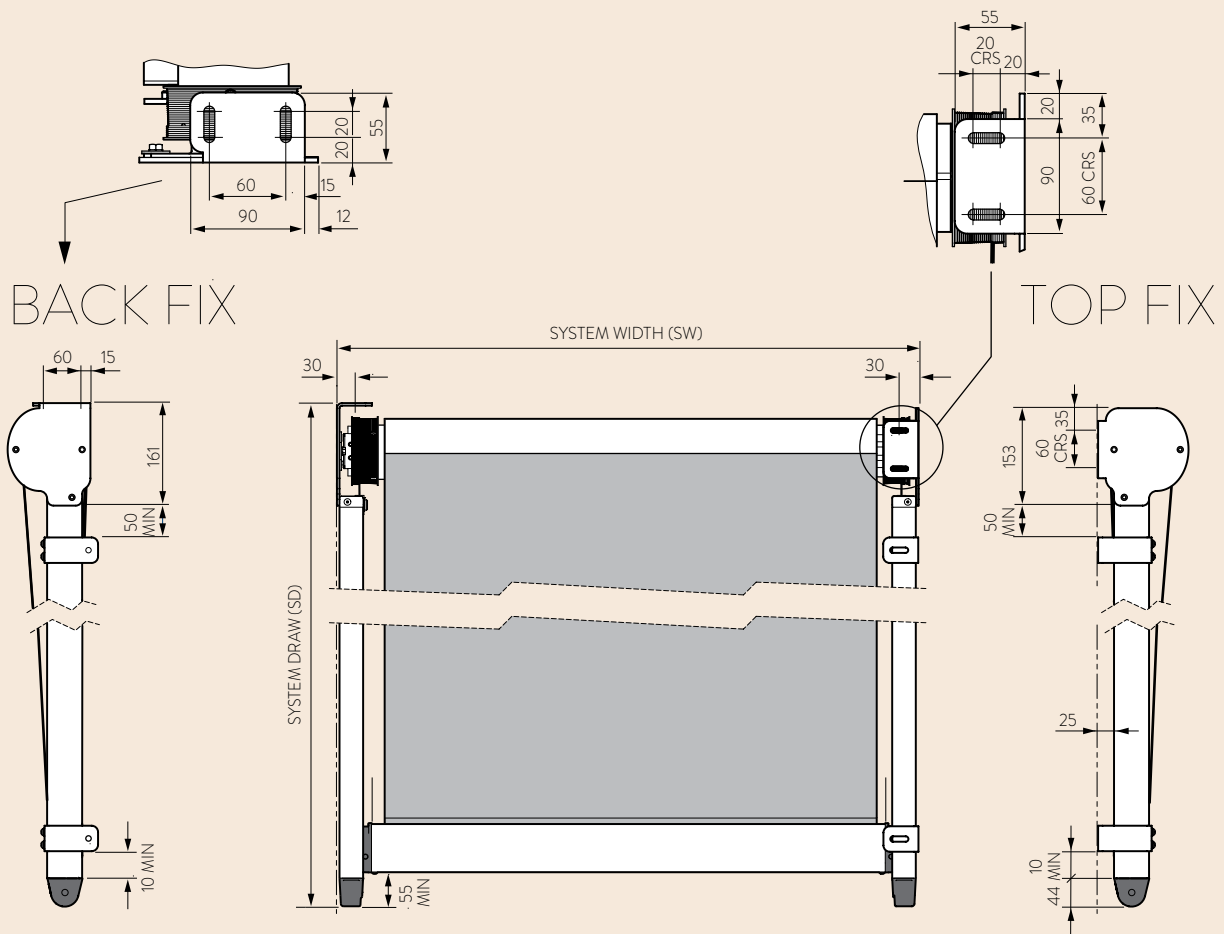

KEYFACTS

Typical use	Light structures, retrofit
Shape	Rectangular
Running direction	Any
Guides	Aluminium profile
Width	870 mm - 4000 mm
Draw	≤6500 mm
Fabric area	≤16 m ²
Brackets	Aluminium
Relieving rollers	Aluminium
Finish	RAL Powder coat
Installation options	Top, back, side

TECHNICALINFO

Fabric tension	>100 N
Weight exc. fabric	~9 kg + 4.2 kg/m width+ 3.1kg/m draw
Fixing load	5 kg per fixing point
Operating temp.	0 to 55 °C
Motor	15 Nm, 17 rpm
Electrical	230 V, 50 Hz, 140 W, 0.65A
	120 V, 60 Hz, 130 W, 1.1A
Max run time	4 min
Fabric speed	~5 m/min
Controls	Radio, Wired

